

Data Sheet



Article number: 2308051582

Description: E+G Index plunger
PMT.100-SST-10-M20x1.5-AK

Measures

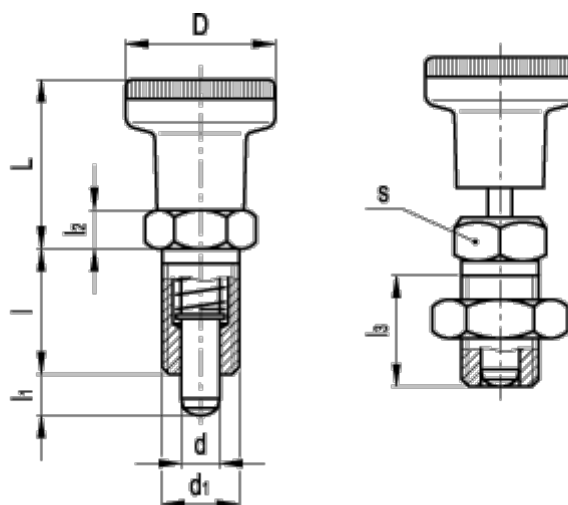

Code = PMT.100-10-M20x1,5-SST-AK

D = 31

d = 10

d1 = M20x1.5

l = 33

L = 37

l1 = 10

l2 = 10

l3 = 30

Max. axial load (N) = 40

s = 22